

VIBRATORS for SAND, GRAVEL & READY MIX CONCRETE PRODUCTS

CONSTRUCTION

We're The Vibrator Guys.

VIBCO

www.vibco.com

WEIGH BATCHERS

The 3 Most Popular Vibrators



VS-320
SILENT TURBINE PNEUMATIC

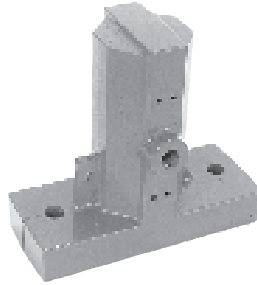

55-1-1/4
PISTON PNEUMATIC

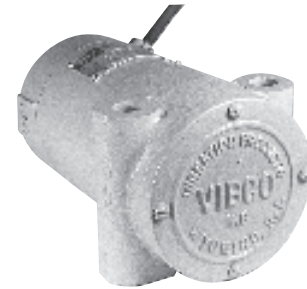

US-450
115 VOLT ELECTRIC

VIBRATORS TO USE:

1. ELECTRIC – MODEL US-450

Advantages:

- Easy to install, connects to any electrical light outlet.
- Only draws 3 amps at 115 volt
- Will Outlast Pneumatic Units 3 to 1
- Quiet Operation
- Can be connected to gate control for automatic on-off
- Can be repaired in the field

Considerations:

- Initial cost higher than a pneumatic unit, but low maintenance & long life more than makes up for initial price
- Maintenance wise the brushes need to be changed every 1000 hours for normal use & 600-700 hours for repeated stop and start duty

2. PNEUMATIC – TURBINE VIBRATORS MODEL VS-320

Advantages:

- Needs no lubrication - bearings pre lubricated for life
- Absolutely quiet
- 72-75 dB no more noise than an electric motor
- Air consumption less than ball vibrators
- Outlasts ball roller and piston vibrators 3 to 1
- Can be repaired in the field, repair kits available

2. PNEUMATIC – TURBINE (cont.)

Considerations:

- Need 3/8" air hose instead of 1/4" hose used by equivalent piston vibrator

3. PISTON VIBRATORS – MODEL 55-1-1/4"

Advantages:

- Use less air to operate than any other pneumatic vibrator
- Lowest in cost of the pneumatic vibrators

Considerations:

- MUST be lubricated - works on same principle as the piston in a car, must have oil or they seize
- Must have relatively clean air – an air cleaner in the line is necessary. A mixture of oil and water in the air line creates a lapping compound and will make the piston seize
- Noisy - is the loudest of all vibrators 85-90dB

4. BALL VIBRATOR – MODEL V-320

Considerations:

- Must have continuous lubrication or it will wear out fast and noise becomes ear shattering
- Loses efficiency fast, especially if lubrication is insufficient

Many other vibrator models can be used but they have other considerations than the above listed ones or are more expensive. Considering the operating cost and life & repair cost of unit, on a long term basis, Model US-450 is the best buy. Second is Model VS-320, then Model 55-1-1/4".

SEE GENERAL CATALOG #9001 FOR TECHNICAL DATA: VS-320 under Turbines, 55-1-1/4" under Piston and US-450 under High Frequency Vibrators.

MODEL US-450 KEEPS CEMENT FLOWING.

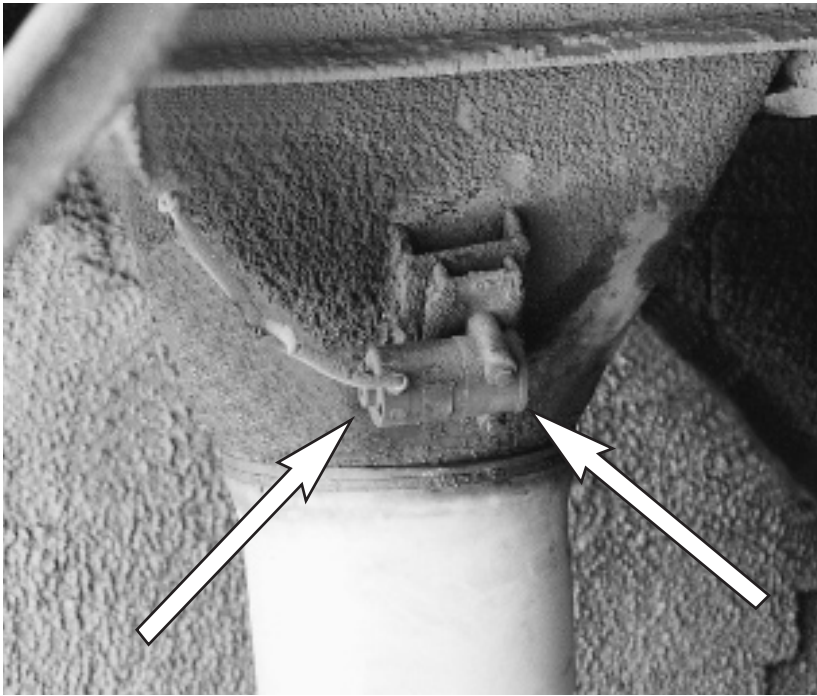

PROBLEM: Dry Portland Cement would cling to weigh batcher, and hopper sides. A 2 x 4 was used to get flow going and clean sides:

SOLUTION: Model US-450 high frequency vibrator was mounted to channel iron that was welded to side of hopper. The high frequency vibration and force loosened the cement and made it flow easily and cleanout was made in a few seconds.

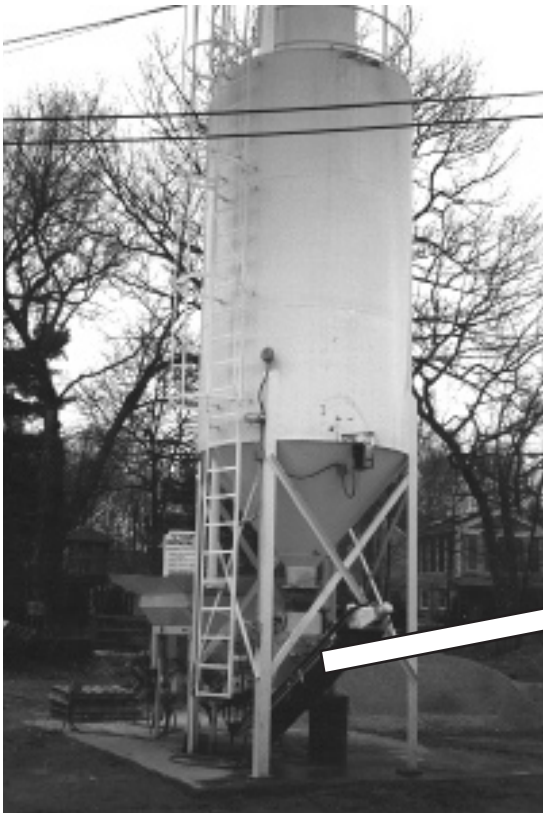

**MODEL VS-320 ON
PORTABLE BATCH
READY MIX PLANT**



To insure fast and accurate batching and reduce noise a Model VS-320 Pneumatic Silent Turbine vibrator was installed on Weigh Batcher.

Every vibrator application is different. The solutions presented in this catalog should not be considered as instructions or recommendations. Please contact VIBCO for assistance selecting a vibrator for your specific application.

Any one of the vibrators listed on page 2 can be used on bins and hoppers. High frequency over 5000 vibrations per minute are most effective for light fluffy materials, cement, etc.

RULE OF THUMB FOR SIZING: Figure out total weight in pounds of material insloping, conical part of bin. Divide by 10, the figure is the total force needed on the vibrator or vibrators to be selected. See General Catalog Model US-450 under High Frequency Vibrators.

US-VIBRATORS AT WORK

CUSTOMER: Ready-Mix plant

APPLICATION: Cement weigh-batcher

PROBLEM: VIBCO US-450T, 115 volt totally enclosed electric vibrator was mounted to batcher (see picture and mounting diagram). Vibrator location for fine cement dust is 1/4 up side with least slope.* The 4" mounting channel is 3' long, stitch welded to 1/4" batcher skin. **The operator switches handy vibrator switch "on" when discharging cement into transit-mix, truck and turns US-450T "off" when dial scale reads zero.

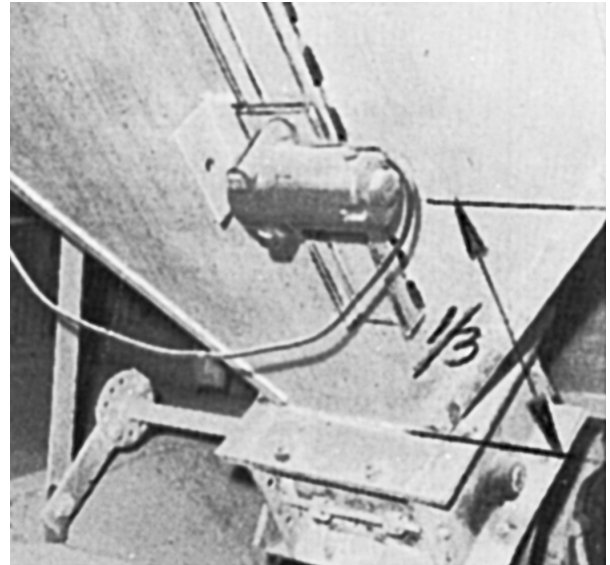

RESULT: Reliable mixes, delivered on time! This VIBCO vibrator in operation over four years without maintenance to unit, batcher or scale. Also,

batcher stays whistle-clean inside with no built up cement to chip off at maintenance time.

PNEUMATIC UNITS:

Comparable pneumatic vibrators are the VS-320, 55-1¹/₄, on thick walled hoppers, the SVRF-4000.

* On coarser materials vibrator is placed about 1/3 up side wall.

** Use longer channel (up to 7') for thinner walls; for plates over 3/8" use 1-2" long channel.

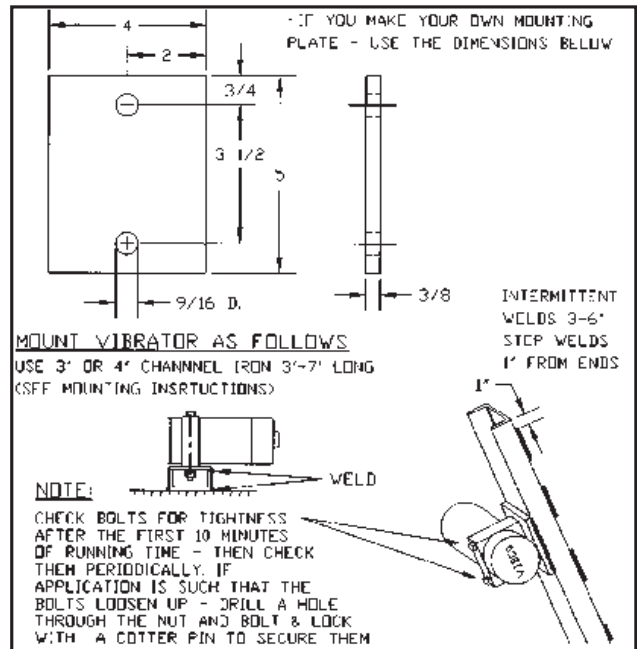

Every vibrator application is different. The solutions presented in this catalog should not be considered as instructions or recommendations. Please contact VIBCO for assistance selecting a vibrator for your specific application.

CEMENT SILOS

Most Popular Vibrators



**PNEUMATIC
VS-510 & CCF**



MODEL 2P-450

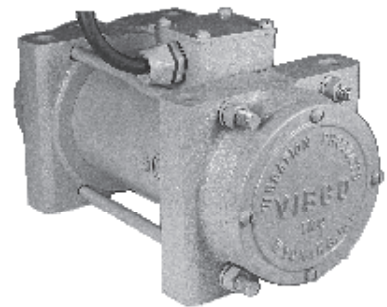

ELECTRIC

MODEL US 1600

Cement reacts well to a vibrator frequency of 3600 vibrations per minute or higher. The high frequency vibration helps to aerate the cement and make it flow freely. Rotary vibrators churn the cement and are better to use than piston and electro-magnetic vibrators that have a tendency to pack the cement.

1. To select the proper size vibrator, calculate the total weight of the material in the sloping part of the silo only.

For rectangular bins: (dimensions in feet):

Length x Width x Height x 1/3 x Material Density in Lbs./Cu.Ft.

For conical bins:

.261 Dia² x Height x Material Density in Lbs./Cu.Ft.

2. If the weight of cement is 1000lbs. in the sloping part of the bin. Divide the total weight from by 10 you will get the vibration force needed on the vibrator.

If the cement silo has a lot of stiffeners or is made of extra heavy steel walls, use one size larger vibrator.

For selecting pneumatic vibrators model VS and CC see Turbine Vibrators in general catalog, for electric vibrators Model US under High Frequency Vibrators and for 2P models under Heavy Duty Vibrators.

Picture shows Model 2P-800 Electric Vibrator on thin walled 10' Dia. Cement Silo. A 7' long 4" channel iron is used to stiffen up and distribute the vibration force over the complete bin side.

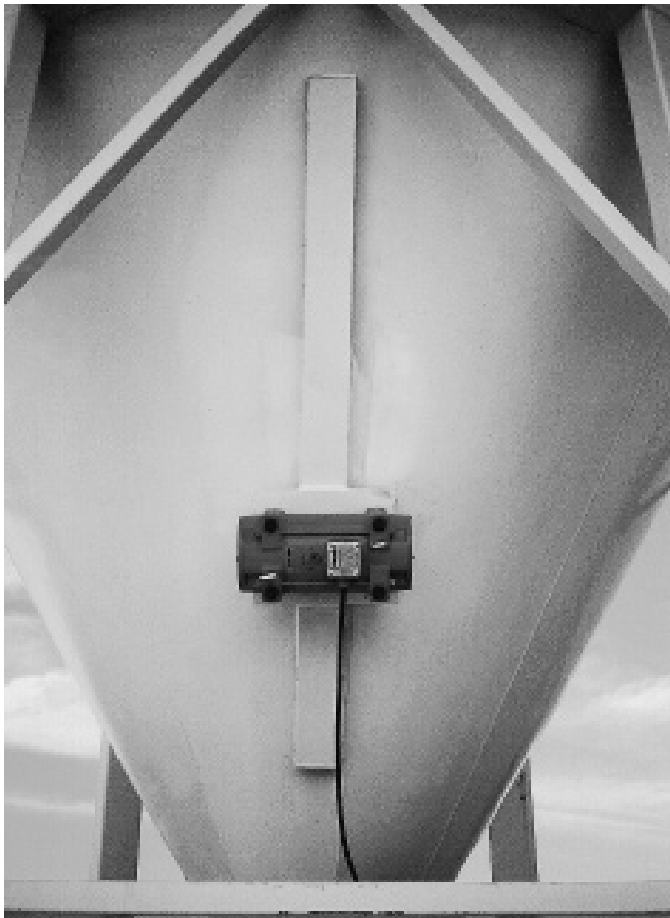

Every vibrator application is different. The solutions presented in this catalog should not be considered as instructions or recommendations. Please contact VIBCO for assistance selecting a vibrator for your specific application.

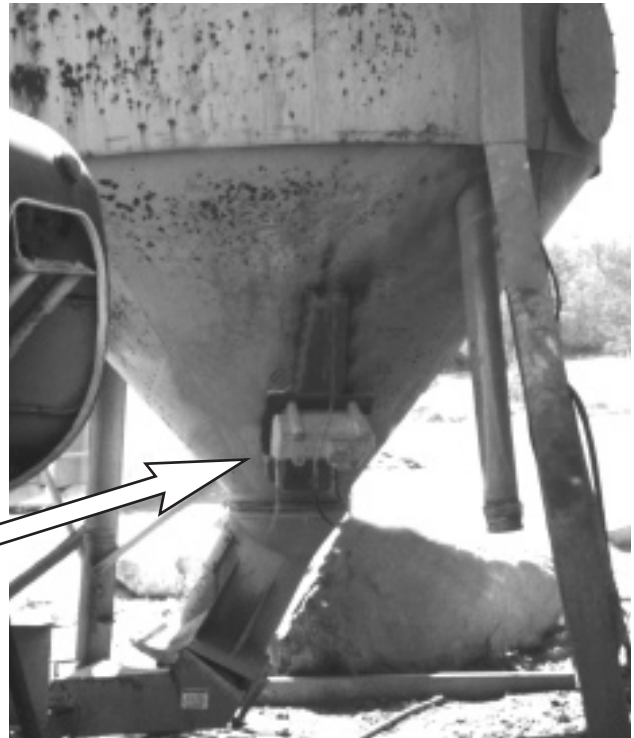

PROBLEM: Cement hung up above chute coming out of hopper

SOLUTION: Model US-1600 Electric Vibrator 115 Volt was installed 1/4 up the slope of the hopper. The high frequency vibrator aerated the cement and made it flow easily thru the chute.



PROBLEM: Flow of cement was erratic from silo and created a constant problem.

SOLUTION: Model US-450 115 volt electric vibrator was installed on a 6" channel iron.

A timer was also installed to start vibrator every 3 minutes to vibrate 20 seconds to keep flow going when cement was drawn from silo.

Every vibrator application is different. The solutions presented in this catalog should not be considered as instructions or recommendations. Please contact VIBCO for assistance selecting a vibrator for your specific application.

AIR CANNON

Prevent Material Sticking to Bin Walls

BRASOTA CONCRETE
3904 15th St. East
Bradenton, FL 33506

PRODUCTS: Lindels and Specialty Blocks

PROBLEM: Despite four aeration nozzles and a couple of old ball vibrators, the discharge of cement from the storage silo was very uneven sometimes non-existent.



SOLUTION: One VIBCO Model ABS-2 Air Cannon was installed as shown in the photos, manually push-button operated from a control panel. With a few initial "blasts" a lot of "old cement" was cleaned out, and now cement flows on command every time. Air consumption has been cut to a fraction of what was used for nozzles and vibrators.

Every vibrator application is different. The solutions presented in this catalog should not be considered as instructions or recommendations. Please contact VIBCO for assistance selecting a vibrator for your specific application.

SAND & GRAVEL

Bins, Hoppers & Chutes

A variety of vibrators are used for these bins and chutes. ELECTRIC, PNEUMATIC and HYDRAULIC. The selection depends on your particular circumstances please call VIBCO application engineers and we will help you make the best selection.

First you must find out how much force is needed on the vibrator to move the material. Too small a vibrator will not do the job no matter if it is electric, pneumatic or hydraulic. Too big a vibrator can damage your bin. To find the correct force needed calculate the weight of material in the transition or sloping part of the bin only.

FOR CONICAL BINS CALCULATE AS FOLLOWS: $261 \times \text{DIA}^2 \times \text{HEIGHT} \times \text{MATERIAL DENSITY IN LBS/CU. FT.}$

FOR RECTANGULAR BINS: $\text{LENGTH} \times \text{WIDTH} \times \text{HEIGHT} \times 1/3 \times \text{MATERIAL DENSITY}$

When the below weight is calculated divide by 10. The figure you get is the force or impact needed on the vibrator. From the table draw a line across from the force calculated. You will then find you have a choice of several vibrators, both electric, pneumatic or hydraulic models.

Vibrator Force or Impact Lbs.	PAGE NO.	ELECTRIC MODELS										PNEUMATIC MODELS										HYDRAULIC MODELS			BIN SKIN Thickness Max.
		2P Page 3-6	4P Page 3-6	6P Page 3-6	8P Page 3-6	SPR Page 9-10	US Page 11-12	SFC Page 9-10	FC Page 9-10	SCR Page 7-8	TURBINE Page 13-18	BALL Page 19-20	PISTON Page 21-22	SVR Page 23-26	BIG BUSTER Page 27-28	TURBINE Page 27-28	BIG BUSTER Page 27-28	BIN SKIN Thickness Max.							
10																						20 Ga.			
20						SPR 20 & 21																20 Ga.			
40						SPR 20 & 21																1/16			
60	2P-75					SPR 20 & 21																1/8			
80	2P-100					SPR 20 & 21																3/16			
100																						1/4			
150	2P-150																					5/16			
200																						5/16			
300	2P-200																					3/8			
400																						3/8			
500	2P-450																					7/16			
600																						7/16			
700																						1/2			
800																						1/2			
900																						1/2			
1000	2P-800																					1/2			
1200																						1/2			
1400	2P-1700																					3/4			
1600																						3/4			
2000																						3/4			
2500	2P-2500																					3/4			
3000																						1			
3500																						1			
4000																						1-1/4			
4500																						1-1/4			
5000																						1-1/4			
6000																						1-1/4			
7000																						1-1/4			
8000																						1-1/4			

Please contact a VIBCO sales engineer or go to vibco.com for the most current product information.

SOME ADDITIONAL CONSIDERATIONS:

When sizing a vibrator to a bin:

1. If bin side angle is below 30 degrees select next larger vibrator.
2. If bin thickness is extra heavy or an excessive amount of stiffeners are present select next larger vibrator
3. On real sticky and hard to move materials it is better to use 2 smaller vibrators instead of one large one. Each one of the smaller vibrators will produce half of the force of one large one.
4. When using 2 vibrators it has been proven the best results have been obtained by using vibrators with different frequencies for example: In electric models use one 3600 RPM vibrator and one 1800 RPM vibrator. The obtained "interference" vibration has proven to move the most stubborn materials.

IN GENERAL:

ROTARY ELECTRIC VIBRATORS are initially higher in cost than pneumatic vibrators, however, the operation cost is considerably less and the difference in price and installation cost is recaptured in a few months of operation.

OTHER CONSIDERATIONS: The electric units have the lowest noise readings 65-70 dB – no more sound than an electric motor. The life expectancy of an electric vibrator is 2-3 times that of a pneumatic one. (See *Heavy Duty Line in General Catalog.*)



2P-450

TURBINE: BALL & PISTON VIBRATORS: The life of pneumatic units is depending on the cleanness of the compressed air and the operating pressure. Maximum operating pressure is 80 PSI, above 80 PSI, the life of the pneumatic vibrator diminishes rapidly. The dBA reading on piston vibrators is 80-115, on the ball vibrators, 80-110. The ONLY pneumatic unit with a dBA reading of 60-80 is the TURBINE VIBRATOR. The least air consuming are the piston vibrators, then the turbine, ball and SVR high frequency vibrators.

TURBINES: (See page Turbine Line in General Catalog)

- Lowest Noise Level of All the Pneumatic Models 60-80dB
- Need No Lubrication - Bearings are Prelubricated for Life
- Can be Repaired in the Field (Repair Kits Available)
- Wide Selection Available from Force or Impacts from 100 to 5000 lbs.
- Moderate Air Consumption



VS-510



CCF-2000

BALL VIBRATORS: (See Ball Vibrator Line in General Catalog)

- Need Lubrication
- Larger models consume excessive amounts of air
- Simple in design
- Noise level after start-out low 70-75 dB but increases over the life of the unit to 90-110 dB
- Lower in cost than turbines but higher than pistons



V-380

PISTON VIBRATORS: (See Piston Line in General Catalog)

- Must have lubrication
- Need air cleaner to assure clean air
- Noisy 80-115 dB
- Lowest in cost of any pneumatic vibrators
- Cannot be repaired in the field
- Once piston or housing is worn the repair cost is close to the cost of a new unit.

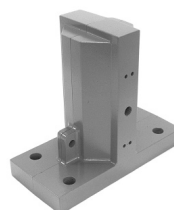

55-3"



PROBLEM: Crushed stone would hang up over clam shell gate.

SOLUTION: Model 2P-800 Electric Vibrator was installed – no more hang ups.

Every vibrator application is different. The solutions presented in this catalog should not be considered as instructions or recommendations. Please contact VIBCO for assistance selecting a vibrator for your specific application.

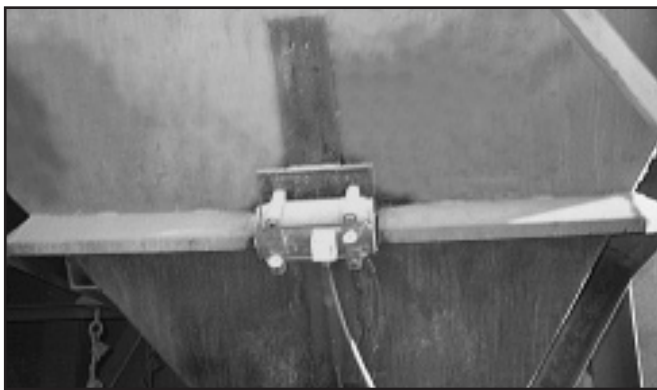
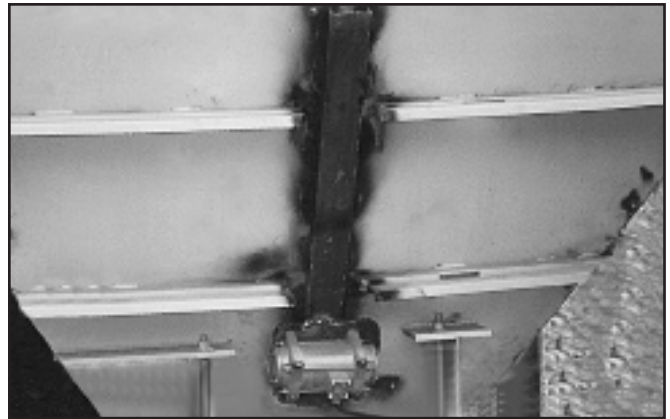
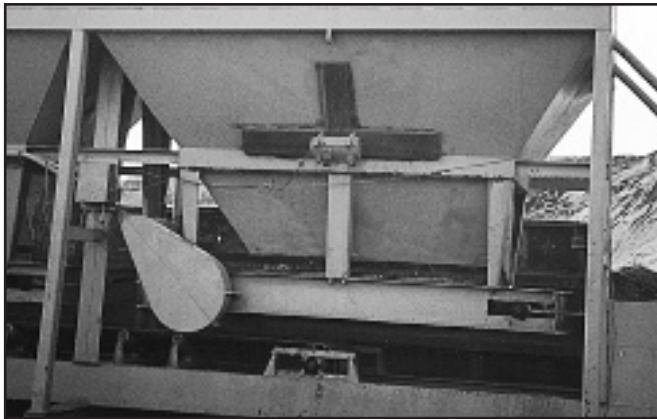

3 DIFFERENT WAYS TO MOUNT A VIBRATOR ON SAND BIN WITH HORIZONTAL STIFFENER

Above Left: Stiffener not strong enough to withstand vibration. A 6" channel was added above stiffener.

Above Right: Stiffeners were cut and a long 4" channel was welded on vertically.

Left: Two 4" channel irons were butted up on each side of the stiffener. Vibrator mounting plate was welded to the top of channel irons and stiffener.

ADDITIONAL APPLICATIONS:

Right: Model 2P-800 on sand bin in cement block plant.

Below Left: SVR 4000 high impact high frequency pneumatic vibrator used on silt bin.

Below Right: CCF-2000 Silent Pneumatic Turbine Vibrator used on gravel hopper.

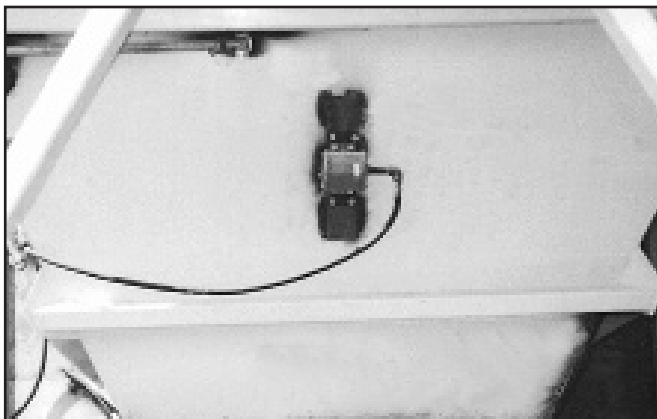
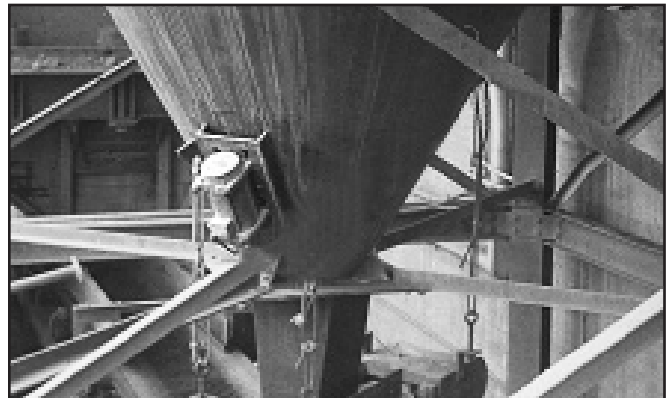

Every vibrator application is different. The solutions presented in this catalog should not be considered as instructions or recommendations. Please contact VIBCO for assistance selecting a vibrator for your specific application.

ENGINEERING DATA & APPLICATIONS

SAND & GRAVEL

BELOW & RIGHT:

MODEL 2P-450

Two heavy duty electric vibrators keep material flowing at crusher plant.

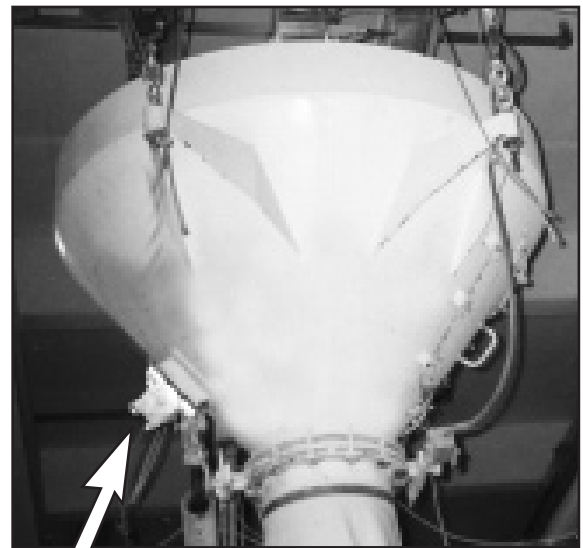
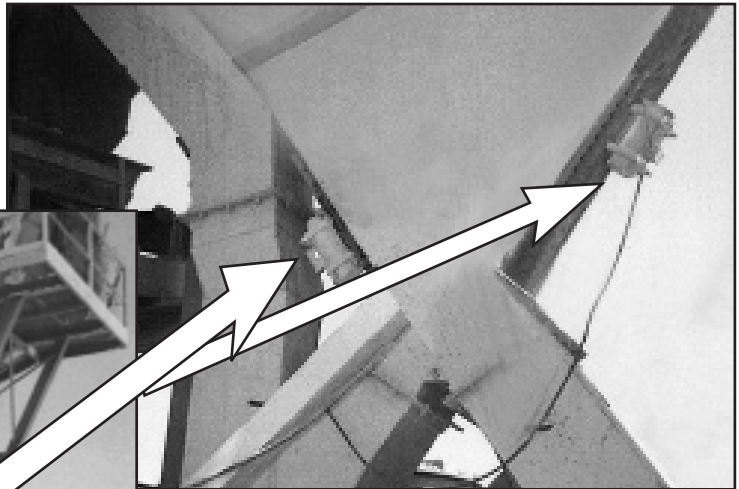

ABOVE:
Model VS-320
Silent pneumatic turbine vibrator on silica sand bin.

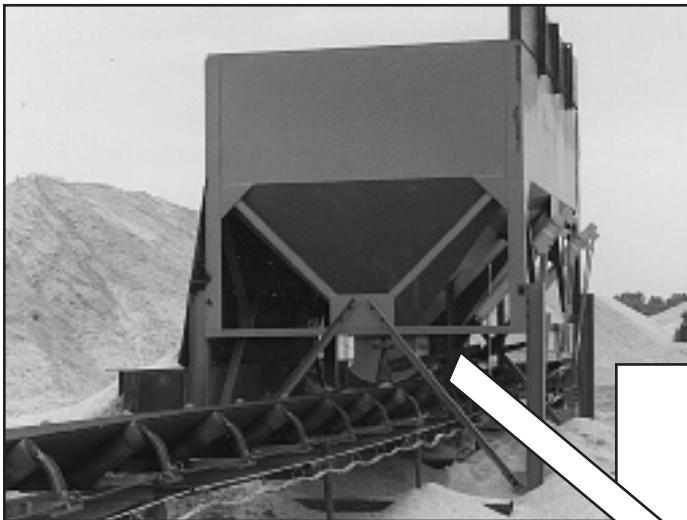

ABOVE & RIGHT:

Model 2P-800

One Model 2P-800 electric heavy duty vibrator unloads two bins onto conveyor belt.

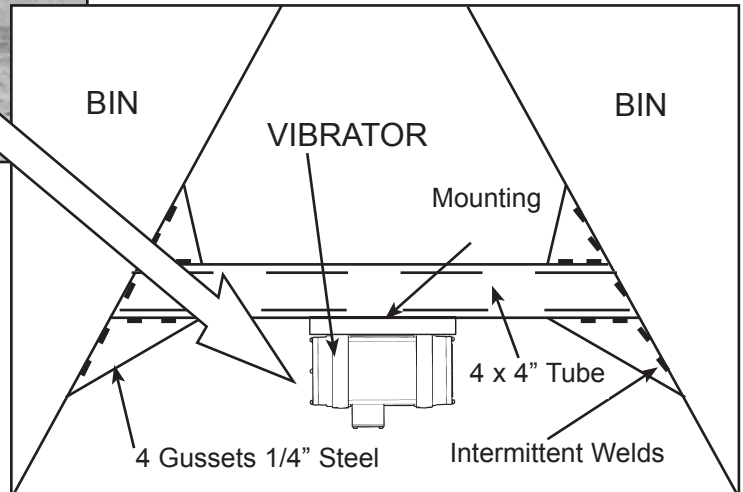

Every vibrator application is different. The solutions presented in this catalog should not be considered as instructions or recommendations. Please contact VIBCO for assistance selecting a vibrator for your specific application.

**HEAVY DUTY MODEL 2P-800
ELECTRIC VIBRATOR CLEANS SAND BIN**

PROBLEM: Wet sand would not flow in bin.

SOLUTION: Model 2P-800 Electric 3 phase vibrator mounted as per below solved the problem.

A. PLACING VIBRATOR

The vibrator should be placed 1/3 up the sloping part of the bin if material is coarse. For fine grain material, 1/4 up.

B. MOUNTING VIBRATOR

Vibrator is never mounted directly to the skin of the bin. Use a plate or preferably a 4" channel which will stiffen up the structure to be vibrated as well as spread the vibration over a large surface.

1. The **channel iron length** is determined by the bin thickness, for 3/16 - 3/8 plate, use 3-5' channel; under 3/16 use 6-7' channel; over 3/8 use 1-2' channel. The channel is welded with legs towards bin if bin skin is over 3/16 or bin is conical. if under 3/16, weld with back towards bin.
2. The **mounting plate** is made of 1/2 - 5/8" plate, make it a wide and as long as the vibrator.
3. **Welding**
 - (a) Weld mounting plate in middle of channel iron.
 - (b) Weld channel iron to bin positioning mounting plate 1/3 or 1/4 up the sloping part of bin. Use intermittent welds 3-6" long. DO NOT WELD THE ENDS. STOP WELDS 1" from ends.

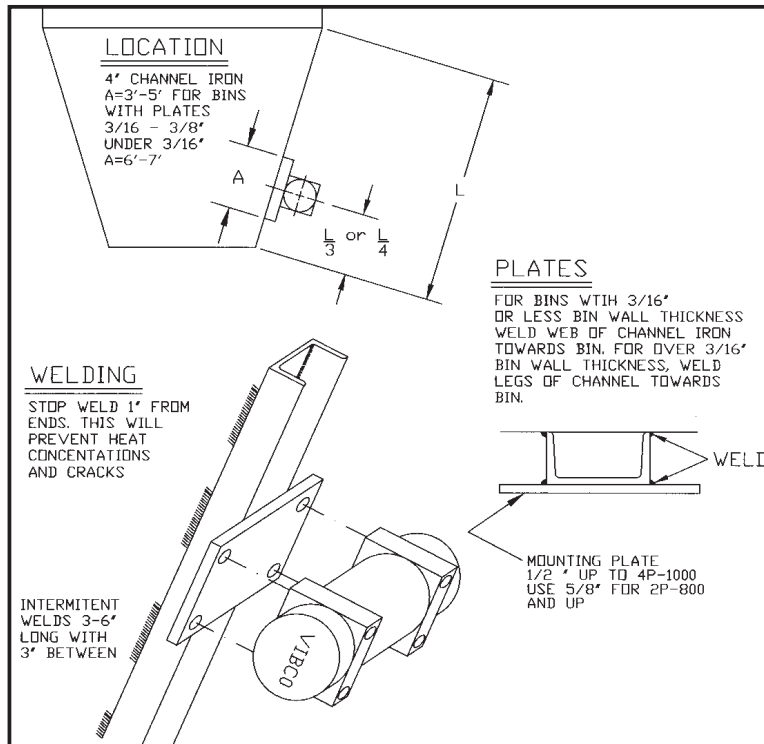
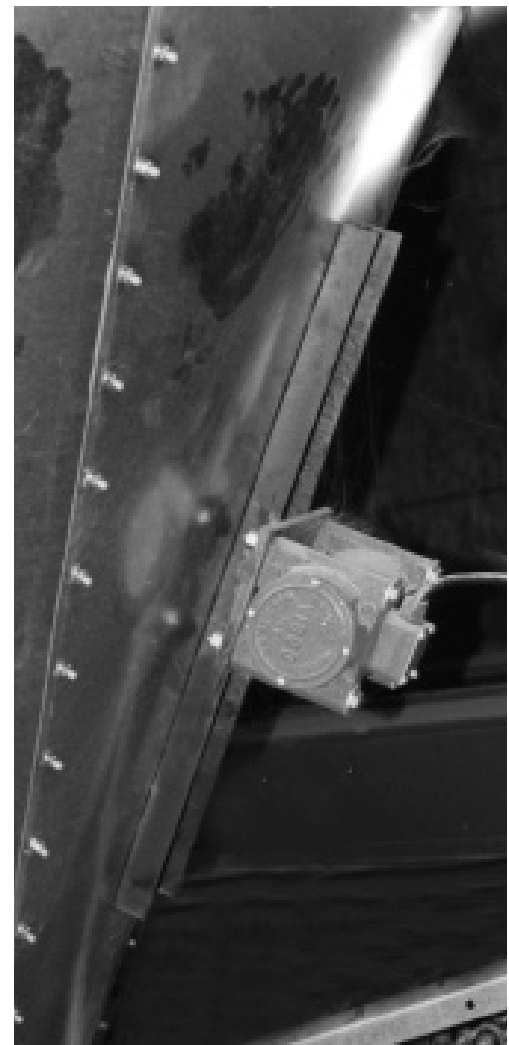

Every vibrator application is different. The solutions presented in this catalog should not be considered as instructions or recommendations. Please contact VIBCO for assistance selecting a vibrator for your specific application.

**VS-250 "SILENT" PNEUMATIC TURBINE
VIBRATOR ON READY MIX CHARGE HOPPER**

- Low Cost Air Vibrator
- Long life, no piston impacting
- Reduce batch time and spillage reduced by minimizing sand buildup
- Reduced vibrator operating noise
- Easy to install:
 - The VS-250 vibrator is controlled by driver in the cab
 - The VS-250 is operated from the truck's air supply
 - No lubrication required for the VS-250



**VS-250
VIBRATOR**

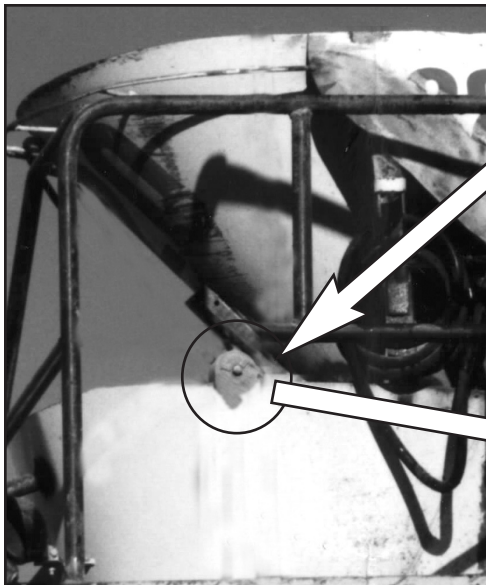

A VS-250 Air Turbine Vibrator mounted on a charge hopper of a front discharge mixer truck.



CUSTOMER COMMENTS: "This small vibrator does a great job of keeping the buildup in the charge hopper clear. I don't have to shovel like I did before. I'm glad they have decided to put one of these vibrators on all the trucks".

Every vibrator application is different. The solutions presented in this catalog should not be considered as instructions or recommendations. Please contact VIBCO for assistance selecting a vibrator for your specific application.

RAILROAD CARSHAKERS

Unloads Railroad Hopper Car Faster, Cleaner and with Less Labor . . .



CCW-5000



SVRWS-6500

MODEL CCW-5000 PNEUMATIC ROTARY PISTON

Replaces conventional noisy pistons. They need no lubrication. Are prelubricated for life. ABSOLUTELY NOISELESS dB as low as 72-75. No more noise than an electric motor. Reversible rotation for easy removal of vibrator from wedge, recommended for cement, gypsum, after vibration to clean out railroad car.



PC-3500



VMC

MODEL SVRWS-6500

High force, high frequency pneumatic rotary vibrator for sand, stone, asphalt, clay, lime.

MODEL PC-3500

Pneumatic or hydraulic clamp-on vibrator for high force, low frequency, ideal for moving coarse materials.



44-3

MODEL VMC-CLAMP-ON and VMW-WEDGE

Electric, heavy duty vibrator - many models are available up to 3500 lbs. of force. Consult Vibco for proper selection.



SVRWS-6500 Unloading Silica Sand



CCW-5000 Unloading Cement

Every vibrator application is different. The solutions presented in this catalog should not be considered as instructions or recommendations. Please contact VIBCO for assistance selecting a vibrator for your specific application.

**ENGINEERING DATA
& APPLICATIONS**

**DUMP TRUCK
VIBRATOR**

BIG BERTHA

**DUMP FAST, CLEAN,
SAFE & SMART**

**Model DC-3500
12 Volt DC
Battery Operated**

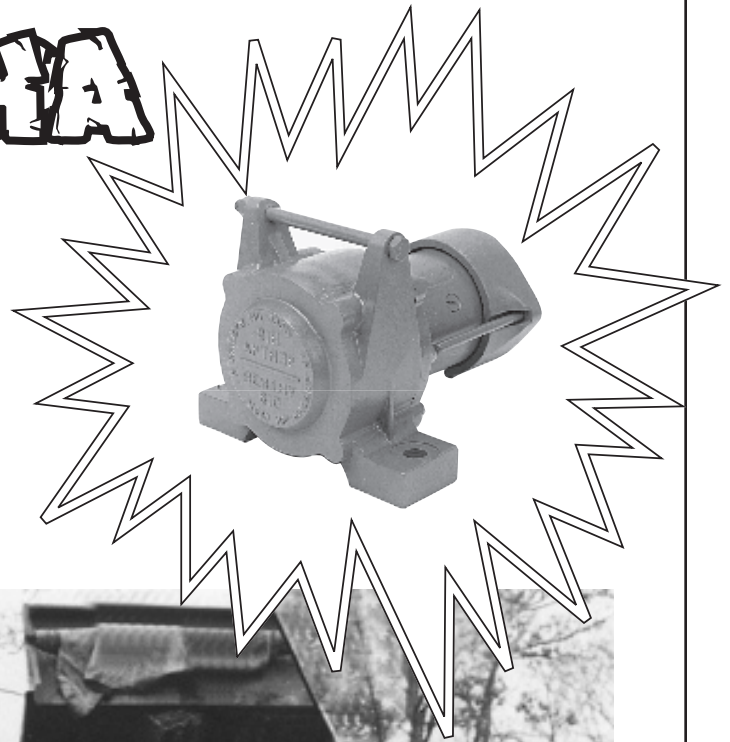

DUMPS CLEAN without having to bang and slam the tailgate. No more shoveling out loads that get stuck. VIBCO's Big Bertha DC-3500 vibrator works fast! Delivering 3500 lbs. of force to release the most stubborn loads. Big Bertha DC-3500 comes with all mounting hardware for quick and easy installation.

Ask for Catalog #0808

800-633-0032

ADDITIONAL VIBCO PRODUCTS:

REVERSIBLE PLATE COMPACTOR

□ THE VIBCO/HEINRICH PLATE COMPACTOR MODEL VR18 has the unbeatable Heinrich basic design and performance (on the market for over 35 years) and Vibco's patented reversible feature added to give you the best performance and quality available and completely made in the U.S.A.

□ VIBCO'S famous warranty applies – Call VIBCO for details about a demonstration of the VR18 Reversible Plate.

□ Once you use a reversible plate you will never use a standard one again – You can compact next to a wall, get into a tight corner, or compact in a ditch & reverse.

□ VIBCO offers a full year warranty on all the parts (Exception: Drive Belt & Engine which follow the engine manufacturer's warranty).

□ VIBCO has been in business since 1962.



Swing over handle – locks in forward or straight up for lifting

Choice of engine – Honda is Standard

Easy reverse/forward shift handle

MODEL VR18

- 18 X 24 LONG PLATE
- 5 HP ROBIN ENGINE
- 3000 LBS. FORCE
- 5000 VIBRATIONS PER MINUTE (ft/min)
- FORWARD SPEED 85 (ft/min)
- REVERSE SPEED 75 (ft/min)
- WEIGHT - 160 LBS.

LIFT HANDLE

Water Tank & Sprinkler System can be added for asphalt work.

Easily removable vibratory element

Heavy duty shocks for longer life and operator comfort

Heavy duty unitized self-cleaning base plate with rounded sides to avoid "dig-down"



CAT. #9606
Internal Concrete Vibrators

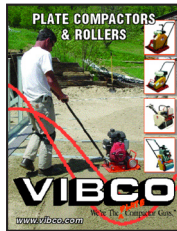

CAT. #9808
Plate Compactors & Rollers



CAT. #0808
12 Volt DC Dump Body Vibrators

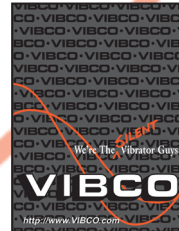

CAT. #9001M
General Catalog

ASK FOR
YOUR FREE
COPY TODAY
SEE US AT www.VIBCO.com

Every vibrator application is different. The solutions presented in this catalog should not be considered as instructions or recommendations. Please contact VIBCO for assistance selecting a vibrator for your specific application.

Please contact a VIBCO sales engineer or go to vibco.com for the most current product information.



We're The Vibrator Guys.™

Corporate HQ & Factory:
75 Stilson Road, P.O. Box 8
Wyoming, RI 02898
E-Mail: vibrators@vibco.com
Phone: (401) 539-2392
(800) 633-0032
FAX: (401) 539-2584

Mid Atlantic US:
Altoona, PA 15942
Phone: (401) 864-5115
(800) 633-0032
FAX: (401) 539-2584

Southeastern US:
St. Petersburg, FL 33716
Phone: (401) 864-5117
(800) 633-0032
FAX: (401) 539-2584

Canada:
2215 Dunwin Drive
Mississauga, ONT L5L 1X1
Phone: (905) 828-4191
(800) 465-9709
FAX: (905) 828-5015

www.vibco.com

PRINTED IN USA
9803C ©2010 VIBCO, INC.