



**EXPERT**  
We're The Vibrator Guys.™

**FAX: 401-539-2584**

**\* = INFORMATION REQUIRED FOR PROPER VIBRATOR RECOMMENDATION**

COMPANY \_\_\_\_\_

CONTACT NAME \_\_\_\_\_

ADDRESS \_\_\_\_\_

PHONE \_\_\_\_\_ FAX \_\_\_\_\_

EMAIL \_\_\_\_\_

**RAILROAD CARS**

Body Construction:  Steel  Other (specify) \_\_\_\_\_

Dimensions: Tonnage: \_\_\_\_\_ Length: \_\_\_\_\_ Width: \_\_\_\_\_ Height: \_\_\_\_\_

**Discharge Information:**

Number of Discharges: \_\_\_\_\_

Wedge pockets: Yes  No

Number of pockets: \_\_\_\_\_

Pneumatic Discharge

Open

Restricted (clam shell)

**Shape of Railcar:**

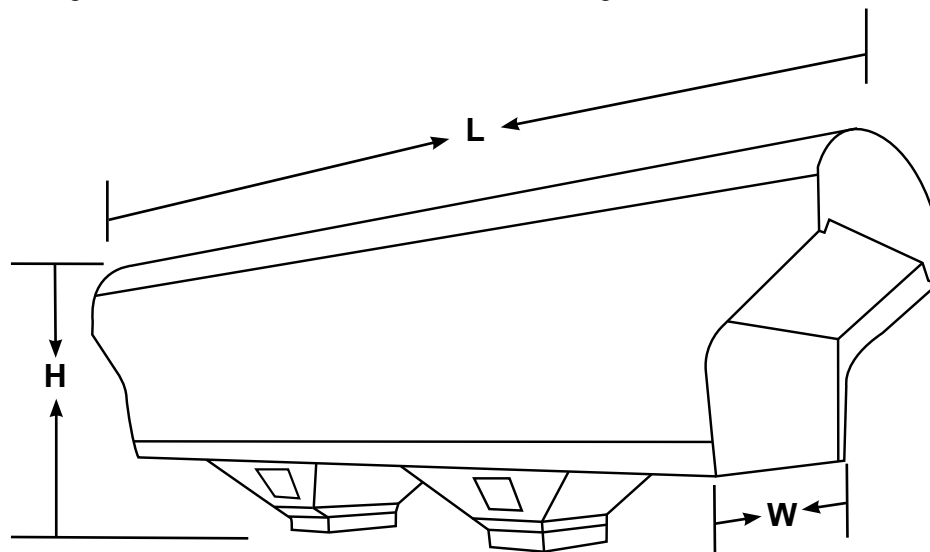

Reason for Vibrator:  Clean out  General Unloading  Other (specify) \_\_\_\_\_

**PLEASE INCLUDE**

engineering drawings & digital picture(s) of application & email them to **vibrators@vibco.com**.

Or please include dimensions & notes regarding your application/problems on this form and fax it to **401-539-2584**.

**MATERIAL BEING HAULED \***

Type of Material: \_\_\_\_\_

Moisture & Texture:  dry  damp  wet  sticky  fine  course

Weight per cubic foot: \_\_\_\_\_ lbs

Discharge Problem:  sticking to sides  sticking to hopper walls OTHER: \_\_\_\_\_

**POWER AVAILABLE - preferred \***

AIR Volume: \_\_\_\_\_ CFM at: \_\_\_\_\_ PSI pressure at vibrators (not at compressor): \_\_\_\_\_

ELECTRIC  Single Phase  Three Phase Voltage: \_\_\_\_\_

HYDRAULIC PSI: \_\_\_\_\_ GPM: \_\_\_\_\_

**VIBCO VIBRATORS RAILCAR INQUIRY DATA SHEET**